

# FlarmACL

Installation manual

Version 1.12



LXNAV d.o.o. • Kidričeva 24a, 3000 Celje, Slovenia • tel +386 592 33 400 fax +386 599 33 522  
[info@lxnav.com](mailto:info@lxnav.com) • [www.lxnav.com](http://www.lxnav.com)

<b>1</b>	<b>Important Notices</b>	<b>3</b>
<b>1.1</b>	<b>Limited Warranty</b>	<b>3</b>
<b>2</b>	<b>Packing Lists</b>	<b>4</b>
<b>3</b>	<b>Installation</b>	<b>5</b>
<b>3.1</b>	<b>Connecting LXNAV FlarmACL</b>	<b>5</b>
<b>3.1.1</b>	<b>Wiring</b>	<b>5</b>
<b>3.1.2</b>	<b>Switch measurements</b>	<b>6</b>
<b>3.1.3</b>	<b>Unit operation</b>	<b>6</b>

## 1 Important Notices

The LXNAV FlarmACL system is designed for VFR use only. All information is presented for reference only. It is ultimately the pilot's responsibility to ensure the aircraft is being flown in accordance with the manufacturer's aircraft flight manual. The FlarmACL must be installed in accordance with applicable airworthiness standards according to the country of registration of the aircraft.

Information in this document is subject to change without notice. LXNAV reserves the right to change or improve their products and to make changes in the content of this material without obligation to notify any person or organisation of such changes or improvements.



A Yellow triangle is shown for parts of the manual which should be read carefully and are important for operating the LXNAV FlarmACL system.



Notes with a red triangle describe procedures that are critical and may result in loss of data or any other critical situation.



A bulb icon is shown when a useful hint is provided to the reader.

### 1.1 Limited Warranty

This LXNAV FlarmACL product is warranted to be free from defects in materials or workmanship for two years from the date of purchase. Within this period, LXNAV will, at its sole option, repair or replace any components that fail in normal use. Such repairs or replacement will be made at no charge to the customer for parts and labour, the customer shall be responsible for any transportation cost. This warranty does not cover failures due to abuse, misuse, accident, or unauthorised alterations or repairs.

THE WARRANTIES AND REMEDIES CONTAINED HEREIN ARE EXCLUSIVE AND IN LIEU OF ALL OTHER WARRANTIES EXPRESSED OR IMPLIED OR STATUTORY, INCLUDING ANY LIABILITY ARISING UNDER ANY WARRANTY OF MERCHANTABILITY OR FITNESS FOR A PARTICULAR PURPOSE, STATUTORY OR OTHERWISE. THIS WARRANTY GIVES YOU SPECIFIC LEGAL RIGHTS, WHICH MAY VARY FROM STATE TO STATE.

IN NO EVENT SHALL LXNAV BE LIABLE FOR ANY INCIDENTAL, SPECIAL, INDIRECT OR CONSEQUENTIAL DAMAGES, WHETHER RESULTING FROM THE USE, MISUSE, OR INABILITY TO USE THIS PRODUCT OR FROM DEFECTS IN THE PRODUCT. Some states do not allow the exclusion of incidental or consequential damages, so the above limitations may not apply to you. LXNAV retains the exclusive right to repair or replace the unit or software, or to offer a full refund of the purchase price, at its sole discretion. SUCH REMEDY SHALL BE YOUR SOLE AND EXCLUSIVE REMEDY FOR ANY BREACH OF WARRANTY.

To obtain warranty service, contact your local LXNAV dealer or contact LXNAV directly.

## **2 Packing Lists**

- LXNAV FlarmACL
- FlarmACL wiring harness

### 3 Installation

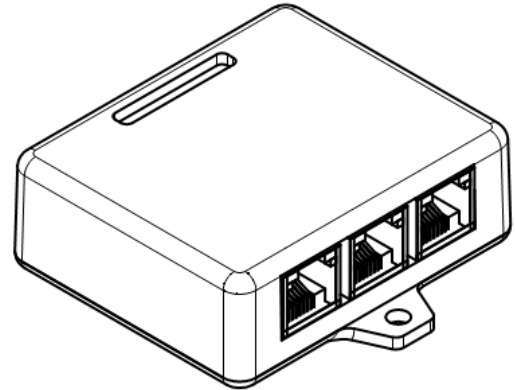
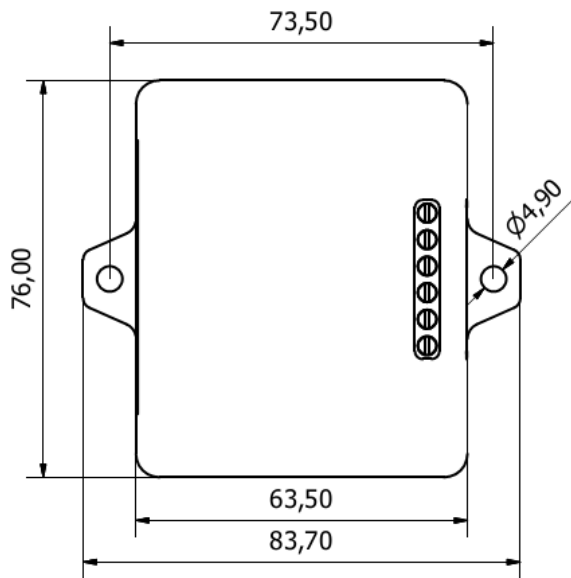

All dimensions in mm

#### 3.1 Connecting LXNAV FlarmACL

##### 3.1.1 Wiring

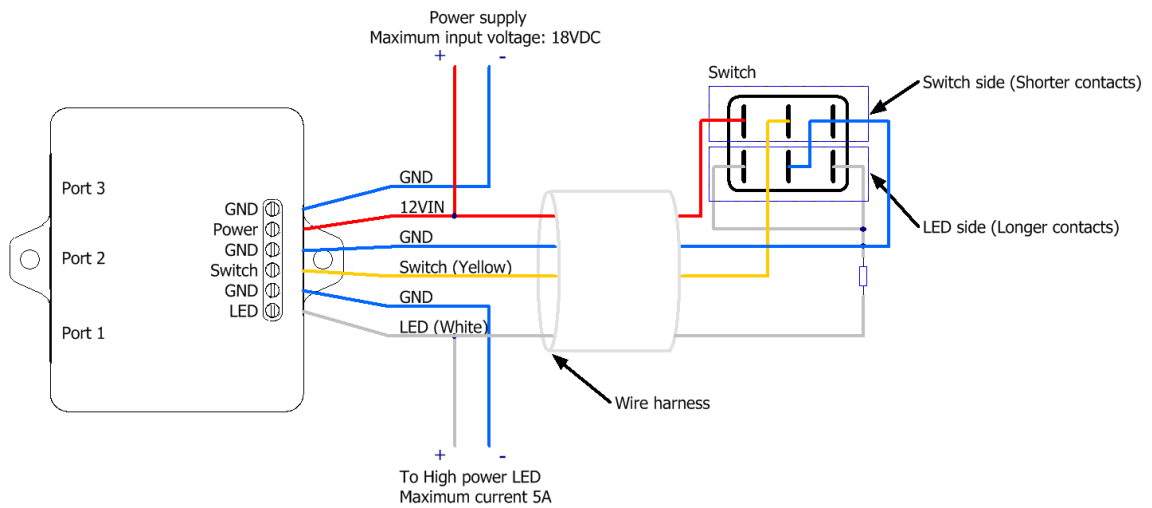

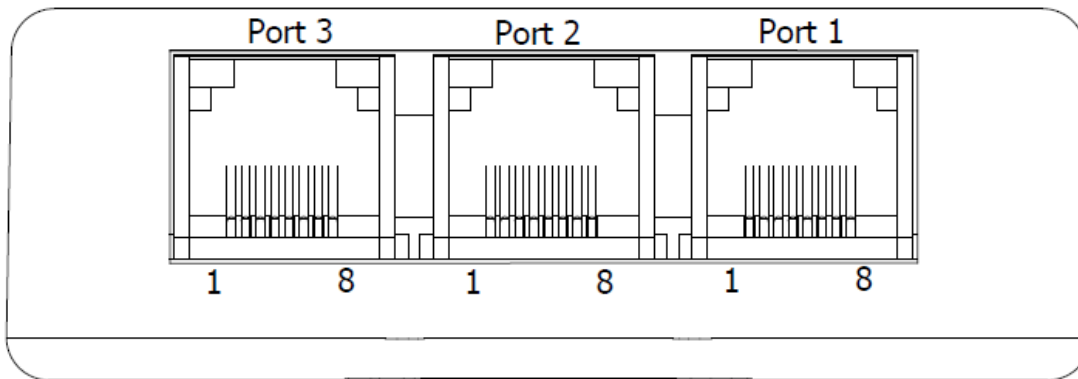

FarmACL connects together Pin 1 from Port 1-3, Pin 2 from Port 1-3, etc. Pin names are:

- 1- +12V
- 2- +12V
- 3- +3,3V (Farm displays)
- 4- GND
- 5- Data Input (Output)
- 6- Data Output (Input)
- 7- GND
- 8- GND

### 3.1.2 Switch description

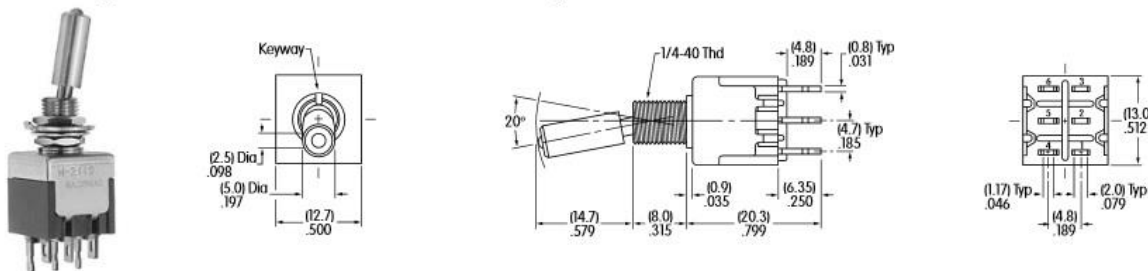

### 3.1.3 Unit operation

FarmACL is powered via external power connection (Screw terminal pin labeled Power). It's own current draw is appr. 30 mA. The device listens to Farm traffic (fixed baudrate of 19200 – newer versions have automatic baudrate detection) on any of the three RJ45 connectors and switches on the connected strobe light via an internal solid state switch (Screw terminal pin labeled LED).

RJ45 connectors also act as a Farm splitter device.

Control is done via the three-position switch with an integrated LED indicator:

- Top position: Output is switched ON, LED indicator is always OFF and green
- Middle position: Output is switched OFF and disabled, LED indicator always OFF
- Bottom position: Output is switched ON only when an urgent alarm is detected, LED indicator is ON and red when this happens. If no alarm is issued for 3 seconds the output is switched OFF.